

NOTE:

1. SUBEXCAVATE SILT LAYER BELOW EXISTING SAND AND GRAVEL FILL MATERIALS, WHICH IS EXPECTED BETWEEN WEST NORTHERN LIGHTS BLVD. AND WEST 27TH AVENUE. SUBEXCAVATION DEPTH IS EXPECTED TO BE ABOUT 3 FT DEEP. SOME SUBEXCAVATION OF THE SILT LAYER MAY BE REQUIRED IN OTHER AREAS, PARTICULARLY AT THE ROAD SHOULDERS WHERE SUBSURFACE CONDITIONS MAY DIFFER FROM THOSE FOUND IN THE GEOTECHNICAL BOREHOLES. BACKFILL SUBEXCAVATION WITH TYPE II CLASSIFIED FILL.

REV	DATE	DESCRIPTION	BY

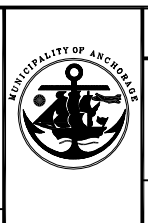
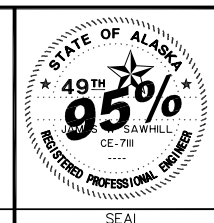
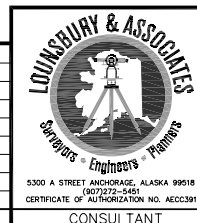

PROJECT MANAGEMENT AND ENGINEERING DEPARTMENT
SCHEDULE A PM&E PROJECT NO. 03-22B
SPENARD ROAD RECONSTRUCTION PHASE II, HILLCREST DRIVE TO BENSON BOULEVARD
TYPICAL SECTIONS
TYPICAL SECTIONS
SCALE: N.T.S. DATE: 12-12-2016 GRIDS: SW1529,1629 SHEET TS1 of TS3
ACCT. NO. 05-037G

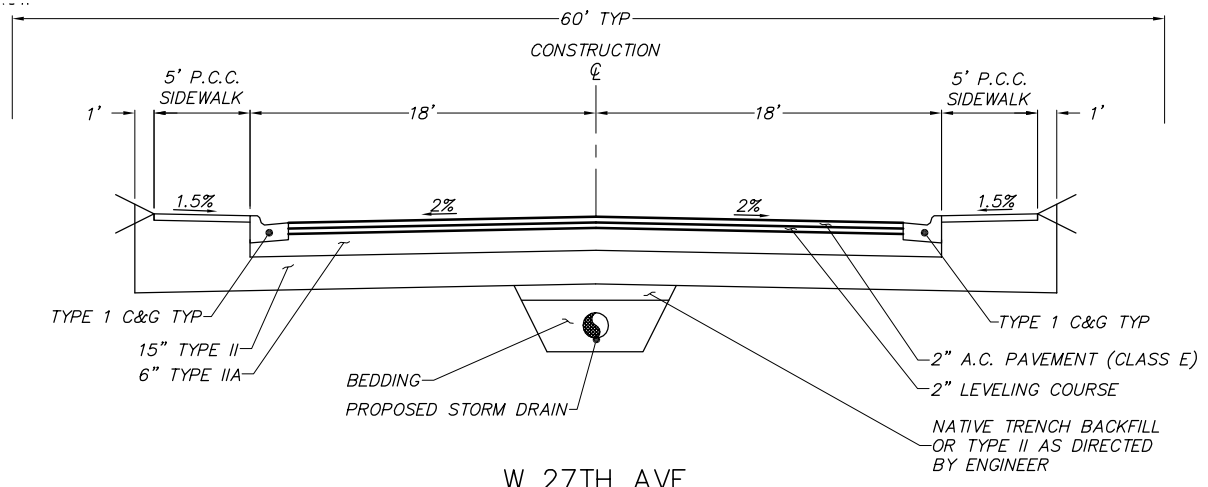

W 27TH AVE
STATION: 399+20.85 TO 401+12.75

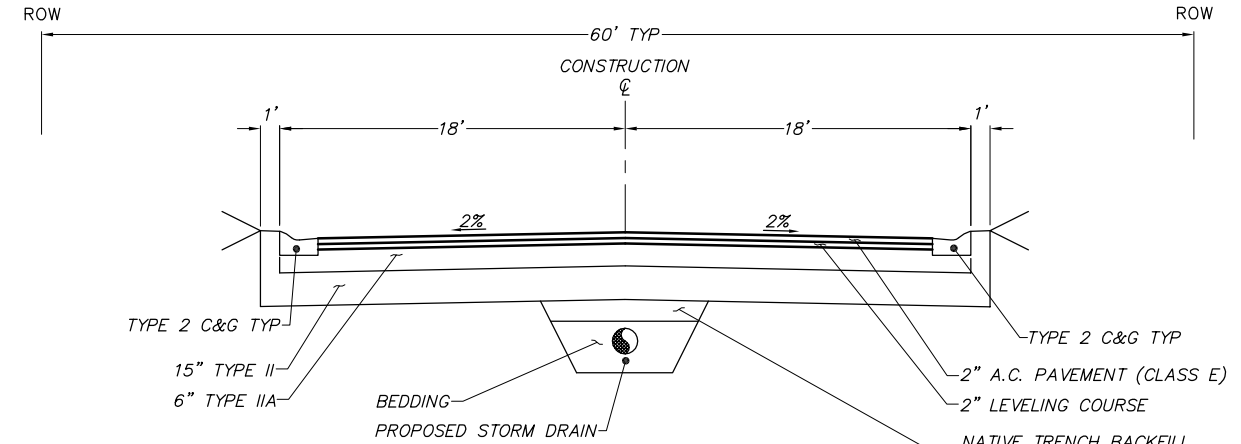

E 27TH AVE
STATION: 401+12.75 TO 402+42.00

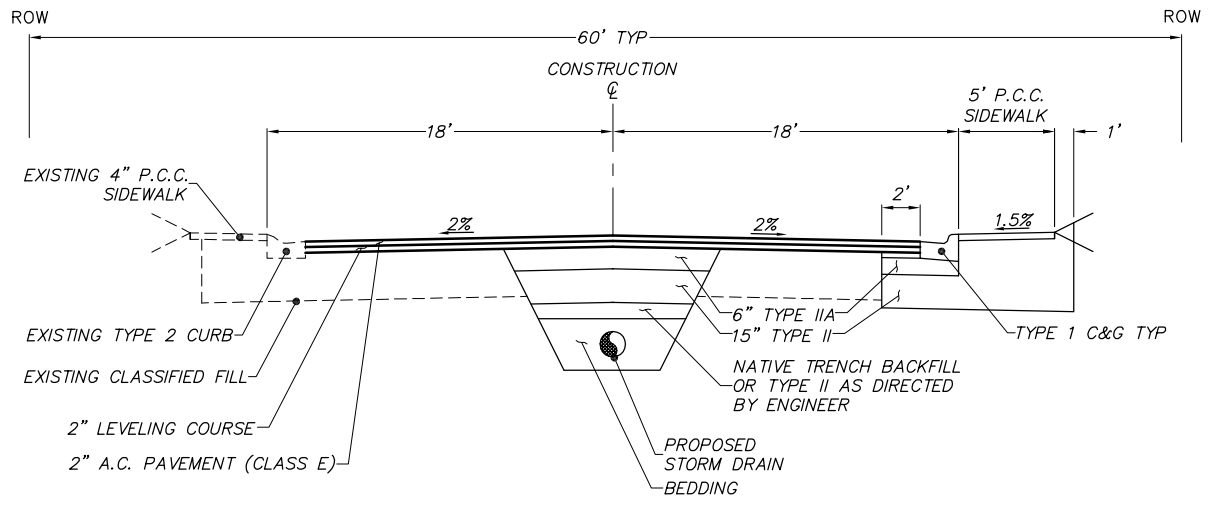

W 27TH AVE
STATION: 398+17.64 TO 399+20.85

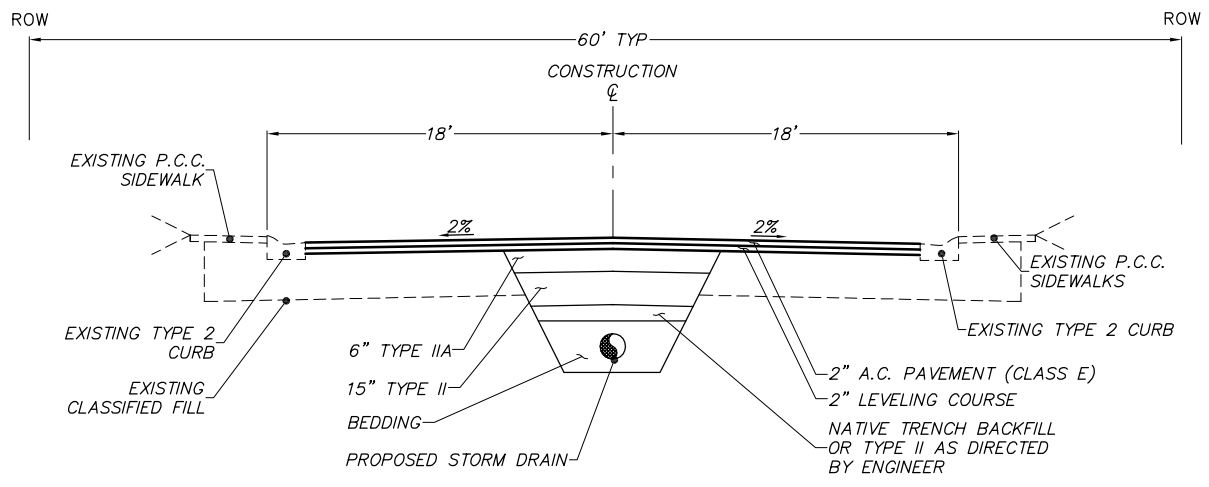

W 27TH AVE
STATION: 397+76.02 TO 398+17.64
PHOTO AVE
STATION: 200+75 TO 202+40

REV	DATE	DESCRIPTION	BY

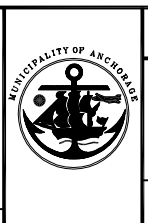
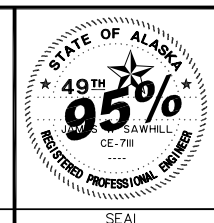
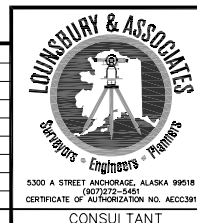

PROJECT MANAGEMENT AND ENGINEERING DEPARTMENT

SCHEDULE A PM&E PROJECT NO. 03-22B

SPENARD ROAD RECONSTRUCTION PHASE II, HILLCREST DRIVE TO BENSON BOULEVARD

TYPICAL SECTIONS

TYPICAL SECTIONS

SCALE: N.T.S.

DATE: 12-12-2016 GRIDS: SW1529,1629 SHEET TS2 of TS3

ACCT. NO. 05-037G

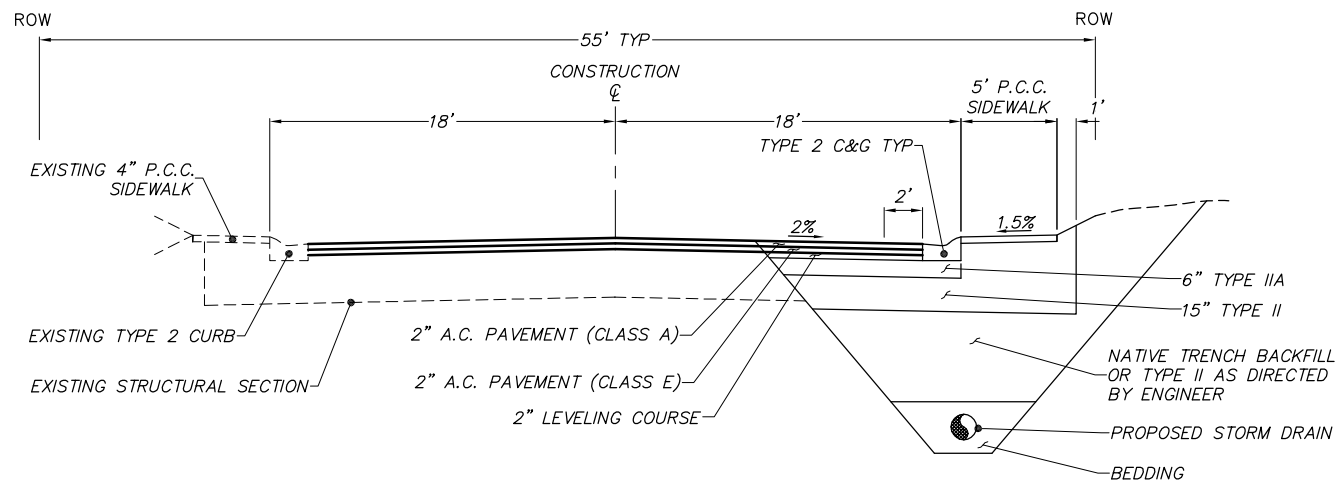

W 23RD AVE
STATION: 7+90 TO 10+00

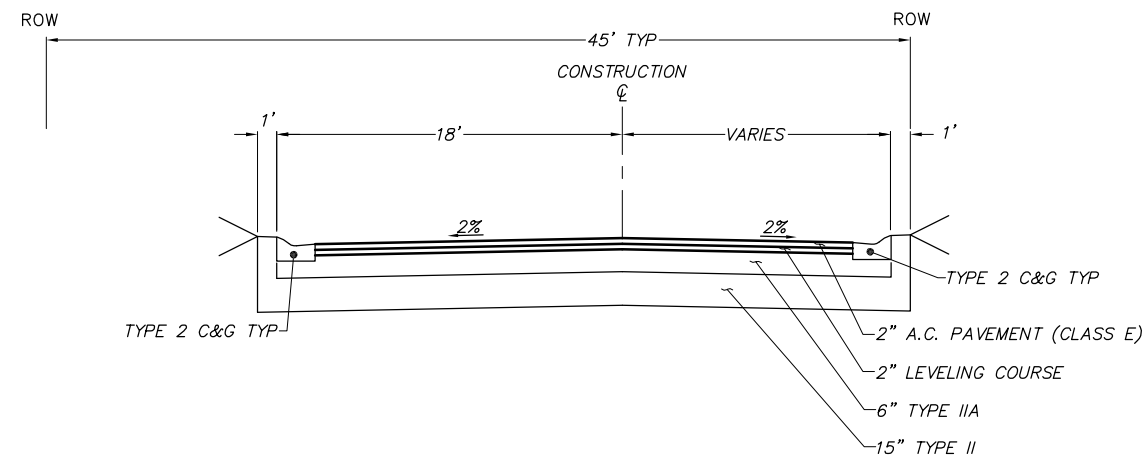

W 25TH AVE
STATION: 10+00 TO 11+09.11

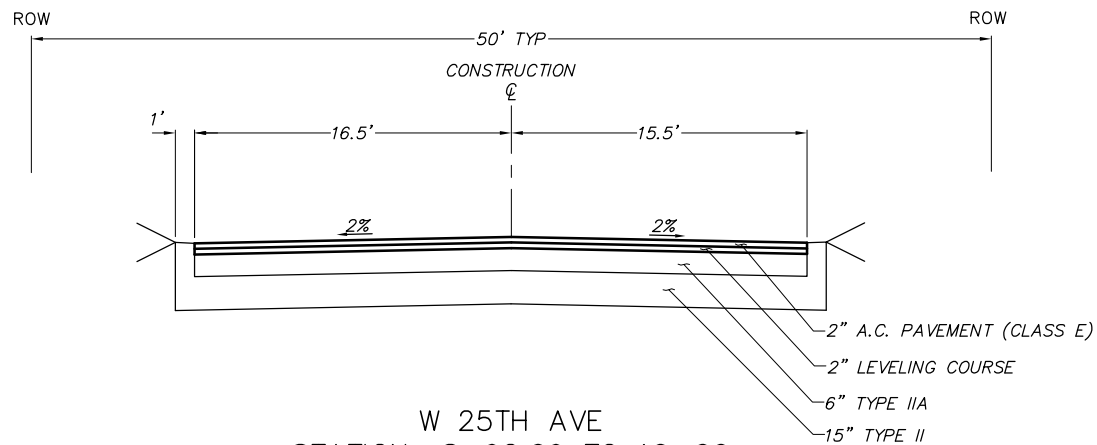

W 25TH AVE
STATION: 8+92.09 TO 10+00

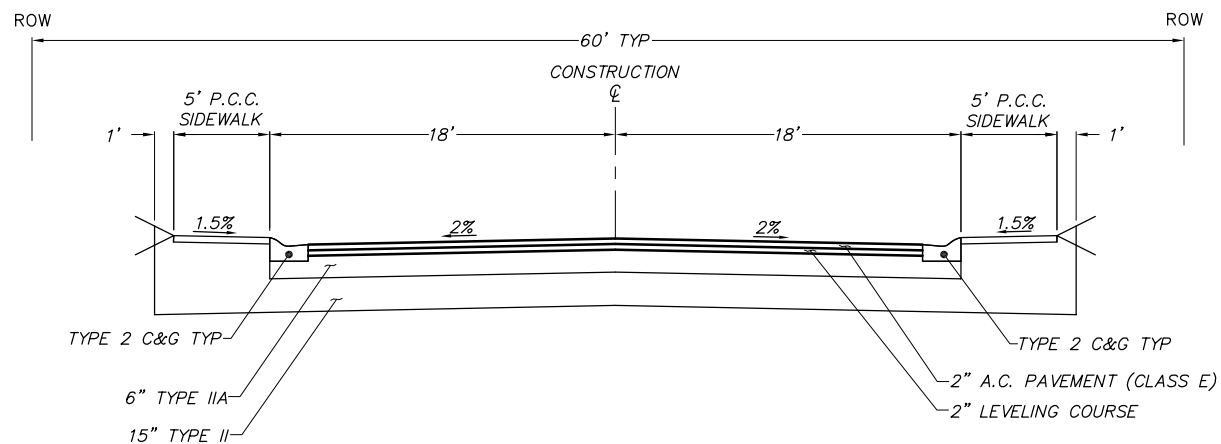

W 26TH AVE
STATION: 498+94.20 TO 500+00

REV	DATE	DESCRIPTION	BY

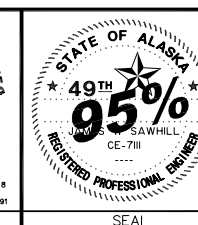
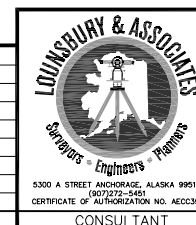

PROJECT MANAGEMENT AND ENGINEERING DEPARTMENT
SCHEDULE A PM&E PROJECT NO. 03-22B
SPENARD ROAD RECONSTRUCTION PHASE II, HILLCREST DRIVE TO BENSON BOULEVARD
TYPICAL SECTIONS
TYPICAL SECTIONS
SCALE: N.T.S. DATE: 12-12-2016 GRIDS: SW1529,1629 SHEET TS3 of TS3
ACCT. NO. 05-037G